

SEMESTER-VI
PHYSICS-DSE: CLASSICAL DYNAMICS
Calculus of variation

Calculus of variation: Variational principle; Euler-Lagrange equations and Hamilton's principle from variational principle, Brachistochrone problem, minimum surface of revolution, motion under gravity, Solution of Hamilton's equation for a particle in a central force field; homogeneity of time and conservation of energy; isotropy of space and conservation of angular momentum.

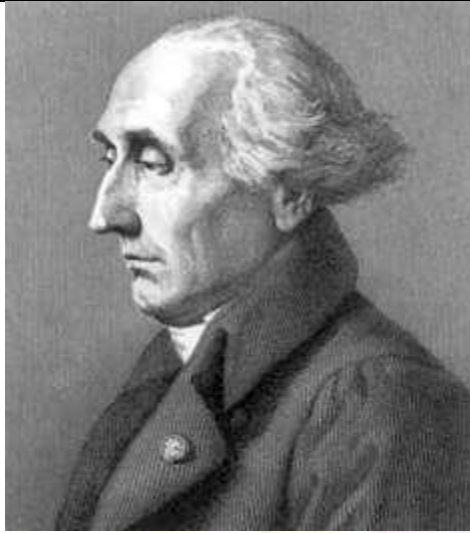

Joseph-Louis Lagrange
(1736-1813)

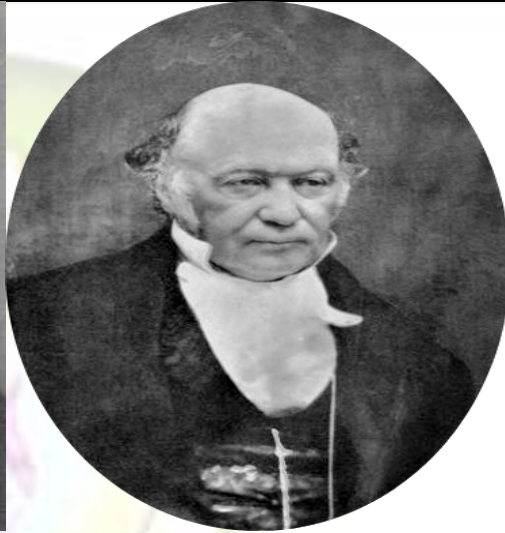

Sir William Rowan Hamilton
(1805-1865)

1. Variational Principle-

From differential calculus, the necessary conditions for maxima or minima of a function $y(x)$ at $x=a$ are given by,

$$y'(a) = 0 \text{ and } y''(a) > 0 \text{ or } < 0$$

Here, $y''(a) > 0$ corresponds to a minima while $y''(a) < 0$ corresponds to a maxima.

The calculus of variation also deals with a similar problem. It seeks to find a path, $y=y(x)$, restricting to one dimension, between two points x_1 and x_2 , such that the line integral over a function of this function $y(x)$ is an extremum. The required condition that $y(x)$ must satisfy in this respect is known as the Euler's equation.

The calculus of variations is a field of mathematical analysis that uses variations, which are small changes in functions and functionals, to find maxima and minima of functionals- mappings from a set of functions to the real numbers. Functionals are often expressed as definite integrals involving functions and their derivatives. Functions that maximize or minimize functionals may be found using the Euler-Lagrange equation of the calculus of variations.

A simple example of such a problem is to find the curve of shortest length connecting two points. If there are no constraints, the solution is a straight line between the points. However, if the curve is constrained to lie on a surface in space, then the solution is less obvious, and possibly many solutions may exist. Such solutions are known as geodesics.

2. Euler-Lagrange equation from variational principle-

Consider a general functional

$$I = \int_a^b F(y, y', x) dx \dots \dots \dots (i)$$

where the values of function y at the end points are fixed. We want to find the function y that minimizes or maximizes I (of course y should satisfy the boundary condition specified above, i.e. the values of $y(a)$ and $y(b)$ are specified and fixed). This problem reduces to finding a function y that can make the variation in I be equal to zero, i.e.

$$\delta I = 0 \dots \dots \dots (ii)$$

We now derive a differential form equivalent to the variational form equation (ii). The variation in I can be calculated as

$$\begin{aligned} \delta I &= \delta \int_a^b F(y, y', x) dx, \\ &= \int_a^b \left(\frac{\partial F}{\partial y} \delta y + \frac{\partial F}{\partial y'} \delta y' \right) dx \dots \dots \dots (iii) \end{aligned}$$

where $\delta y'$ is the variation of y' ,

which can be further written as

$$\delta y' = \delta \left(\frac{dy}{dx} \right) = \frac{d(\delta y)}{dx} \dots \dots \dots (iv)$$

Then the second term on the right-hand side of equation (iii) can be written as

$$\int_a^b \left(\frac{\partial F}{\partial y'} \delta y' \right) dx = \int_a^b \left(\frac{\partial F}{\partial y'} \frac{d\delta y}{dx} \right) dx = \int_a^b \left(\frac{\partial F}{\partial y'} d\delta y \right) = \frac{\partial F}{\partial y'} \delta y \Big|_a^b - \int_a^b \delta y d \left(\frac{\partial F}{\partial y'} \right) \dots \dots \dots (v)$$

Since we require the values of y at the end points, a and b , be fixed, i.e., $\delta y = 0$ at the end points, the above equation is written as

$$\int_a^b \left(\frac{\partial F}{\partial y'} \delta y' \right) dx = - \int_a^b \delta y d \left(\frac{\partial F}{\partial y'} \right) = - \int_a^b \delta y \frac{d}{dx} \left(\frac{\partial F}{\partial y'} \right) dx \dots \dots \dots (vi)$$

Using this, equation (iii) is written as

$$\delta I = \int_a^b \delta y \left[\frac{\partial F}{\partial y} - \frac{d}{dx} \left(\frac{\partial F}{\partial y'} \right) \right] dx \dots \dots \dots (vii)$$

Thus $\delta I = 0$ is written as $\int_a^b \delta y \left[\frac{\partial F}{\partial y} - \frac{d}{dx} \left(\frac{\partial F}{\partial y'} \right) \right] dx = 0 \dots \dots \dots (viii)$

Noting that equation (viii) must hold for arbitrary δy , the only way that can make this possible is

$$\frac{\partial F}{\partial y} - \frac{d}{dx} \left(\frac{\partial F}{\partial y'} \right) = 0 \dots \dots \dots (ix)$$

Equation (ix) is known as Euler-Lagrange equation, which is a differential equation for $y(x)$. The solution to the Euler-Lagrange equation gives the function that can maximize or minimize the functional I .

3. Hamilton's principle and its modified form-

The Hamilton's principle postulates that –“The motion of dynamical system from time t_1 to time t_2 is such that the line integral

$$\int_{t_1}^{t_2} L dt = I$$

is an extremum i.e. stationary for the correct path of the motion”.

In terms of calculus of variation, the principle states that $\delta I=0$ i.e.,

$$\delta \int_{t_1}^{t_2} L dt = \delta \int_{t_1}^{t_2} (T - V) dt = \delta I = 0 \dots \dots \dots (i)$$

The above equation may also be written as,

$$\delta \int_{t_1}^{t_2} L dt = 0 \text{ i.e. } \delta \int_{t_1}^{t_2} L(q_i, \dot{q}_i, t) dt = 0$$

But, the relation between Lagrangian L and Hamiltonian H is given by,

$$H(p_i, q_i, t) = \sum_i p_i \dot{q}_i - L(q_i, \dot{q}_i, t)$$

i.e. $L = \sum_i p_i \dot{q}_i - H$

So, from equation (i), we have,

$$\delta \int_{t_1}^{t_2} (\sum_i p_i \dot{q}_i - H) dt = 0 \dots \dots \dots (ii)$$

This is referred as the modified Hamilton's principle.

4. Hamilton's equations from variational principle-

Let $q_1, q_2, q_3, \dots, q_n$ be the generalized coordinates and $p_1, p_2, p_3, \dots, p_n$ be the generalized momenta of a dynamical system.

We know that,

$$H(p_i, q_i, t) = \sum_i p_i \dot{q}_i - L(q_i, \dot{q}_i, t)$$

$$\text{i.e. } L(q_i, \dot{q}_i, t) = \sum_i p_i \dot{q}_i - H(p_i, q_i, t) \dots \dots \dots (i)$$

Taking δ - variation, $\delta L = \sum(p_i \delta \dot{q}_i + \dot{q}_i \delta p_i) - \{ \sum \frac{\partial H}{\partial p_i} \delta p_i + \sum \frac{\partial H}{\partial q_i} \delta q_i \}$

Integrating between the limits t_1 and t_2 , we get

$$\int_{t_1}^{t_2} \delta L dt = \int_{t_1}^{t_2} [\sum(p_i \delta \dot{q}_i + \dot{q}_i \delta p_i)] dt - \int_{t_1}^{t_2} [\sum \frac{\partial H}{\partial p_i} \delta p_i + \sum \frac{\partial H}{\partial q_i} \delta q_i] dt \dots \dots \dots (ii)$$

Now, according to Hamilton's principle, $\delta \int_{t_1}^{t_2} L dt = 0$

So, equation (ii) becomes,

$$\int_{t_1}^{t_2} [\sum(p_i \delta \dot{q}_i + \dot{q}_i \delta p_i)] dt - \int_{t_1}^{t_2} [\sum \frac{\partial H}{\partial p_i} \delta p_i + \sum \frac{\partial H}{\partial q_i} \delta q_i] dt = 0 \dots \dots \dots (iii)$$

$$\begin{aligned} \text{Now, } \int_{t_1}^{t_2} \sum (p_i \delta \dot{q}_i) dt &= \sum \int_{t_1}^{t_2} p_i \frac{d}{dt} (\delta q_i) dt = \sum \{ [p_i \delta q_i]_{t_1}^{t_2} - \int_{t_1}^{t_2} \frac{d}{dt} (p_i) \delta q_i dt \} \\ &= - \int_{t_1}^{t_2} \sum \dot{p}_i \delta q_i dt \quad (\text{As } \delta q_i = 0, \text{ at end points}) \end{aligned}$$

Putting this value in equation (iii) we get,

$$\begin{aligned} \int_{t_1}^{t_2} \left[\sum \left\{ -\dot{p}_i \delta q_i + \dot{q}_i \delta p_i - \frac{\partial H}{\partial p_i} \delta p_i - \frac{\partial H}{\partial q_i} \delta q_i \right\} \right] dt &= 0 \\ \text{or, } \int_{t_1}^{t_2} \left\{ \sum \left(\dot{q}_i - \frac{\partial H}{\partial p_i} \right) \delta p_i - \left(\dot{p}_i + \frac{\partial H}{\partial q_i} \right) \delta q_i \right\} dt &= 0 \dots \dots \dots \text{(iv)} \end{aligned}$$

If δq_i 's and δp_i 's are independent of each other, then equation (iv) is satisfied only when the coefficients of δq_i 's and δp_i 's separately vanish, that is, when,

$$\frac{\partial H}{\partial p_i} = \dot{q}_i$$

$$\text{and } \frac{\partial H}{\partial q_i} = -\dot{p}_i \quad (\text{where } i = 1, 2, 3, \dots, n)$$

which are Hamilton's equation.

5. Brachistochrone problem (Shortest time problem)-

Let a particle in a conservative force field \vec{F} moves initially from rest and moves to point (x_1, y_1) . To find the path followed by the particle for which the time of transit between the points is a minima, let coordinate system is so oriented that the initial point of rest coincides with the origin $(0, 0)$ of the system.

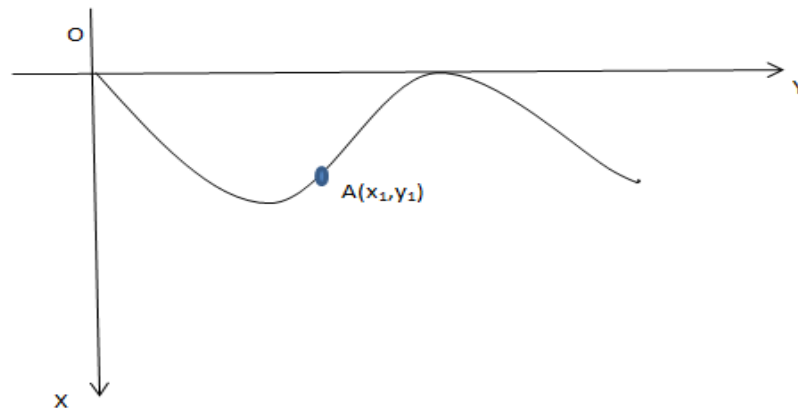

The time of transit is given by,

$$t_{12} = \int_1^2 \frac{ds}{v} \dots \dots \dots \text{(i)}$$

where v is the speed of the particle and ds the separation between the two space points.

As the force field is conservative and frictionless, the total energy i.e. the sum of kinetic energy (T) and potential energy (V) is constant.

Taking $V=0$ at $x=0$ level, $T+V=0$ at the origin. At any point (x,y) in its path,

$$T = \frac{1}{2}mv^2 \text{ and } V = -Fx = -mgx$$

where g is the acceleration of the particle due to the force.

$$\text{So, we have, } v = \sqrt{2gx} \dots \dots \dots \text{ (ii)}$$

Now, equation (i) becomes,

$$t_{12} = \int_1^2 \frac{ds}{v} = \int_0^{x_1} \sqrt{(1+y'^2)/2gx} dx \dots \dots \dots \text{ (iii)}$$

The function f may be written as

$$f = \sqrt{\frac{1+y'^2}{2gx}} \text{ and for } t \text{ to be minimum,}$$

$$\frac{d}{dx} \left(\frac{\partial f}{\partial y'} \right) - \frac{\partial f}{\partial y} = 0 \dots \dots \dots \text{ (iv)}$$

Here, $\frac{\partial f}{\partial y} = 0$ and $\frac{\partial f}{\partial y'} = \frac{y'}{\sqrt{2gx}\sqrt{(1+y'^2)}}$

Putting this in equation (iv) we get,

$$\frac{d}{dx} \left(\frac{y'}{\sqrt{2gx}\sqrt{(1+y'^2)}} \right) = 0$$

$$\text{or, } \frac{y'}{\sqrt{2gx}\sqrt{(1+y'^2)}} = C, \text{ constant}$$

$$\text{or, } \frac{y'^2}{c^2} = x(1+y'^2)$$

$$\text{or, } y'^2 \left(\frac{1}{c^2} - x \right) = x$$

$$\text{or, } y'^2 = \frac{x}{b-x} \text{ where } b=1/c^2, \text{ a constant}$$

$$\text{or, } \frac{dy}{dx} = \sqrt{\frac{x}{b-x}}$$

$$\text{or, } y = \int \sqrt{\frac{x}{b-x}} dx + C', C' \text{ is another constant}$$

Let $x = b\sin^2\theta$, then $dx = 2b\sin\theta\cos\theta d\theta$

Therefore, $y = \int \frac{\sin\theta}{\cos\theta} 2b\sin\theta\cos\theta d\theta + C'$

$$\begin{aligned} &= b \int 2\sin^2\theta d\theta + C' = b \int (1 - \cos 2\theta) d\theta + C' = b \left[\theta - \frac{\sin 2\theta}{2} \right] + C' \\ &= \frac{b}{2} [2\theta - \sin 2\theta] + C' \end{aligned}$$

Then the parametric equations of the curve are,

$$x = b\sin^2\theta = \frac{b}{2} [1 - \cos 2\theta]$$

$$\text{and } y = \frac{b}{2} [2\theta - \sin 2\theta] + C'$$

Since the curve passes through (0,0), $C' = 0$

Therefore,

$$x = \frac{b}{2} [1 - \cos 2\theta]$$

and

$$y = \frac{b}{2} [2\theta - \sin 2\theta]$$

Let $2\theta = \phi$ and $\frac{b}{2} = a$. Then the parametric equations of the curve are,

$$x = a(1 - \cos \phi)$$

and

$$y = a(\phi - \sin \phi)$$

This represents a cycloid. The constant a can be determined because the curve passes through the point (x_1, y_1) .

6. Minimum surface of revolution-

Let AB be a curve which passes through two fixed points $A(x_1, y_1)$ and $B(x_2, y_2)$. Let curve AB is revolved about Y-axis to generate a surface. Consider a strip of the surface whose radius is x and breadth is $PP' = ds$.

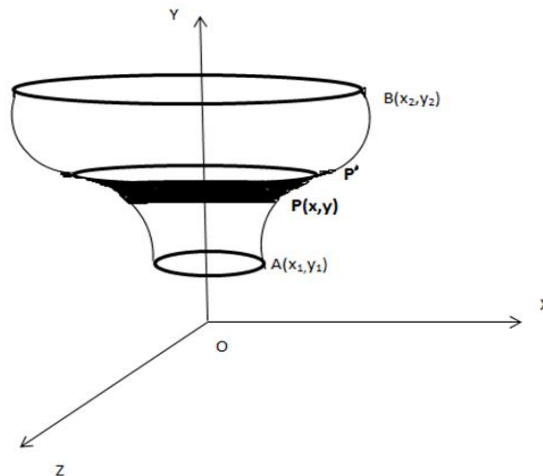

Here, $ds^2 = dx^2 + dy^2$. or, $ds = \sqrt{1 + y'^2} dx$ (where $y' = dy/dx$)

Area of the strip is $dS = 2\pi x ds = 2\pi x \sqrt{1 + y'^2} dx$

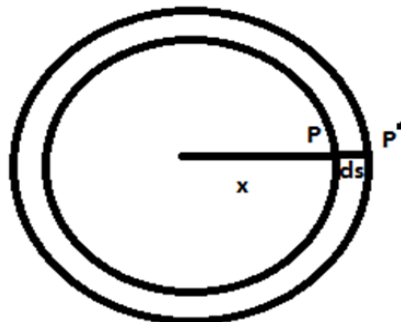

So, total area of revolution is $S = 2\pi \int_A^B x \sqrt{1 + y'^2} dx \dots \dots \dots$ (i)

This area will be extremum if $\delta S = 0$, for which Euler-Lagrange equation is to satisfied

$$\text{i.e. } \frac{d}{dx} \left(\frac{\partial f}{\partial y'} \right) - \frac{\partial f}{\partial y} = 0 \dots \dots \dots$$
 (ii)

$$\text{where } f = x \sqrt{1 + y'^2}$$

Here, $\frac{\partial f}{\partial y} = 0, \left(\frac{\partial f}{\partial y'} \right) = \frac{xy'}{\sqrt{1+y'^2}}$

Putting these values in equation (ii) we get,

$$\frac{d}{dx} \left(\frac{xy'}{\sqrt{1+y'^2}} \right) = 0 \text{ or, } \frac{xy'}{\sqrt{1+y'^2}} = a \dots \dots \dots$$
 (iii)

where a is constant.

On squaring equation (iii), we get,

$$x^2 y'^2 = a^2 + a^2 y'^2 \text{ or, } y' = \frac{dy}{dx} = \frac{a}{\sqrt{x^2 - a^2}}$$

Therefore, $y = \int \frac{a}{\sqrt{x^2 - a^2}} dx = a \text{ Cosh}^{-1} \frac{x}{a} + b \dots \dots \dots$ (iv)

where b is another constant.

From equation (iv) we have,

$$a \text{ Cosh}^{-1} \frac{x}{a} = \frac{y-b}{a} \text{ or, } x = a \text{ Cosh} \frac{y-b}{a} \dots \dots \dots$$
 (v)

This is the equation of the curve for which the surface of revolution is minimum. Equation (v) is the equation of a catenary. The two constants a and b can be determined by the condition that the curve (v) passes through points (x_1, y_1) and (x_2, y_2) .

7. Motion under gravity-

Let a particle of mass m is falling freely under gravity and covers a distance z in time t. The kinetic energy and potential energy of the particle in time t are $\frac{1}{2} m \dot{z}^2$ and $-mgz$ respectively.

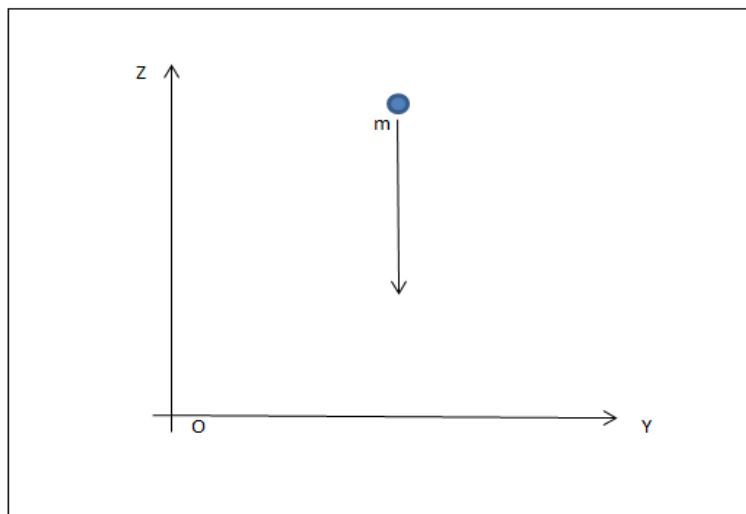

The Lagrangian of the particle is given by, $L = T - V = \frac{1}{2}m\dot{z}^2 + mgz$

By Hamilton's principle we can write,

$$\delta \int \left(\frac{1}{2}m\dot{z}^2 + mgz \right) dt = 0$$

If $f(z, \dot{z}, t) = \frac{1}{2}m\dot{z}^2 + mgz$, then the path $f(z, \dot{z}, t)$ would be extremum if f satisfies Euler-Lagrange equation,

$$\frac{d}{dt} \left(\frac{\partial f}{\partial \dot{z}} \right) - \frac{\partial f}{\partial z} = 0 \dots\dots\dots (i)$$

Here, $\frac{\partial f}{\partial \dot{z}} = m\dot{z}$ and $\frac{\partial f}{\partial z} = mg$

Putting these values in equation (i) we get,

$$m\ddot{z} - mg = 0$$

$$\text{or, } \ddot{z} - g = 0$$

This is the equation of motion of a particle under gravity.

8. Solution of Hamilton's equation for a particle in a central force field-

All central forces are conservative in nature and can be given by,

$$F(r) = -\frac{\partial V}{\partial r}$$

Now, from inverse square law we can write,

$$F = -\frac{k}{r^2} = -\frac{\partial V}{\partial r}$$

$$\text{So, } V(r) = -\frac{k}{r}$$

If m be the mass of a particle moving in the central force field, then the Hamiltonian is given by,

$$H = T + V(r) = \frac{1}{2}m(\dot{r}^2 + r^2\dot{\theta}^2) - \frac{k}{r} \dots\dots\dots (i)$$

The generalized momenta of the particle are,

$$p_r = mv_r = m\dot{r} \text{ and } p_\theta = mr^2\dot{\theta}$$

Hence, the generalized velocities are,

$$\dot{r} = \frac{p_r}{m} \text{ and } \dot{\theta} = \frac{p_\theta}{mr^2}$$

So, equation (i) becomes,

$$H = \frac{p_r^2}{2m} + \frac{p_\theta^2}{2mr^2} - \frac{k}{r}$$

There are four Hamilton's equations- two for q and two for p .

The equations are,

$$\dot{r} = \frac{\partial H}{\partial p_r} = \frac{p_r}{m}$$

$$\dot{\theta} = \frac{\partial H}{\partial p_\theta} = \frac{p_\theta}{mr^2}$$

$$\dot{p}_r = -\frac{\partial H}{\partial r} = \frac{p_\theta^2}{mr^3} - \frac{k}{r^2}$$

$$\dot{p}_\theta = -\frac{\partial H}{\partial \theta} = 0$$

Since $p_\theta = mr^2\dot{\theta}$, so the third equation can also be written as,

$$m\ddot{r} = mr^2\dot{\theta}^2 - \frac{k}{r^2}$$

$$\text{or, } m\ddot{r} - mr^2\dot{\theta}^2 = -\frac{k}{r^2}$$

In terms of angular momentum $L = mr^2\dot{\theta}$, the above equation may be written as,

$$m\ddot{r} - \frac{L^2}{mr^3} = -\frac{k}{r^2}$$

This is the equation of motion of the particle in central force field.

9. Homogeneity of time and conservation of energy-

If the physical properties of a closed system remain unchanged for any arbitrary shift in the origin of time then the condition is known as Homogeneity of time.

A closed system is described by its Lagrangian and the homogeneity of time dictates that it is not dependent on time explicitly so that we have

$$\frac{\partial L}{\partial t} = 0.$$

The total time derivative of L is,

$$\frac{dL}{dt} = \sum_j \frac{\partial L}{\partial q_j} \frac{\partial q_j}{\partial t} + \sum_j \frac{\partial L}{\partial \dot{q}_j} \frac{\partial \dot{q}_j}{\partial t} + \frac{\partial L}{\partial t}$$

The above equation can also be rewritten using Lagrange's equation as,

$$\frac{dL}{dt} = \sum_j \frac{d}{dt} \left(\frac{\partial L}{\partial \dot{q}_j} \right) \dot{q}_j + \sum_j \frac{\partial L}{\partial \dot{q}_j} \frac{\partial \dot{q}_j}{\partial t} \quad (\text{as } \frac{\partial L}{\partial t} = 0)$$

$$\text{or, } \frac{dL}{dt} = \sum_j \frac{d}{dt} \left(\dot{q}_j \frac{\partial L}{\partial \dot{q}_j} \right)$$

$$\text{or, } \frac{d}{dt} \left[\sum_j \dot{q}_j \frac{\partial L}{\partial \dot{q}_j} - L \right] = 0$$

This implies that the function $H = \sum_j \dot{q}_j \frac{\partial L}{\partial \dot{q}_j} - L = \text{Conserved} \dots \dots \dots (i)$

During the motion of a mechanical system nq_j and $n\dot{q}_j$ (which specify the state of a system) vary with time (Here n is the number of degrees of freedom of the system). However, there exist some functions of these quantities whose values remain constant during the motion, and depend only on the initial conditions. Such functions are known as integrals of motion. The quantities represented by such integrals of motion are said to be conserved. Equation (i) represents such an integral of motion. We also know that H i.e. Hamiltonian represents the total mechanical energy of the system.

It thus follows that the total mechanical energy of a closed system is conserved because of the homogeneity of time.

10. Isotropy of space and conservation of angular momentum-

If for any arbitrary rotation about the origin of the reference frame the physical properties of a closed system remain unaffected, we say that the space is isotropic. Thus every

direction in space is equivalent to every other direction for the description of the state of motion of a closed system.

Because of this isotropy of space, a closed system when rotated as a whole in space in any manner whatsoever, its mechanical properties does not vary. So, the Lagrangian of a closed system should not be affected ($\delta L=0$) in any infinitesimal rotation $\delta\vec{\phi}$ as a whole.

Let \vec{r} be the position vector of a particle in respect to the origin O. Let OO' be the axis of rotation. The increase in the magnitude of position vector caused by rotation $\delta\vec{\phi}$ about OO' is, $|\delta\vec{r}| = r \sin\theta \delta\phi$.

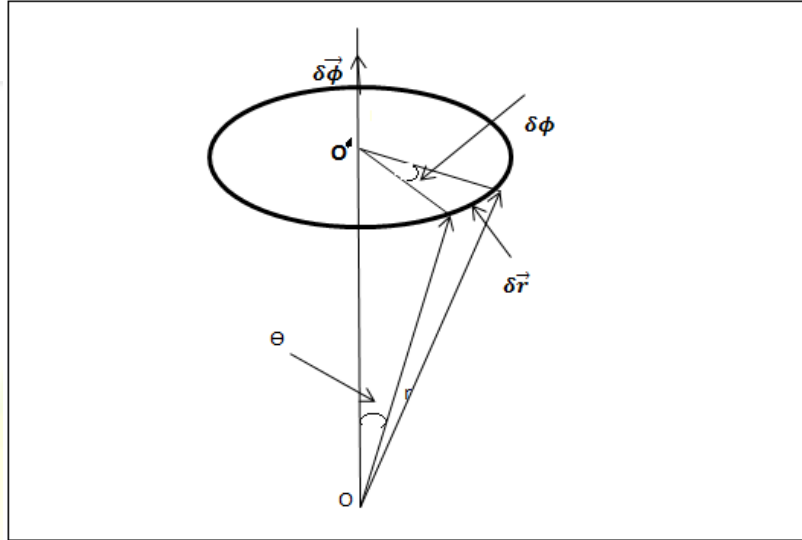

The rotation $\delta\vec{\phi}$ can be treated as a vector of magnitude equal to the angle of rotation $\delta\phi$ and of direction \hat{n} along the axis of rotation.

The displacement of the end of the position vector is thus,

$$\delta\vec{r} = \delta\vec{\phi} \times \vec{r} \text{ by the right-handed screw rule.}$$

But, the rotation also causes a change in the direction of the particle velocities \vec{v} in the same manner with respect to a fixed frame of reference.

$$\text{Therefore, } \delta\vec{v} = \delta\vec{\phi} \times \vec{v}$$

We can write,

$$\begin{aligned} \delta L &= \sum_j \left(\frac{\partial L}{\partial \vec{r}_j} \cdot \delta\vec{r}_j + \frac{\partial L}{\partial \vec{v}_j} \cdot \delta\vec{v}_j \right) \\ &= \sum_j (\dot{\vec{p}}_j \cdot \delta\vec{\phi} \times \vec{r}_j + \vec{p}_j \cdot \delta\vec{\phi} \times \vec{v}_j) \dots \dots \dots \text{(i)} \end{aligned}$$

Now, for a rotation of the system as a whole, $\delta\vec{\phi}$ is the same for every particle.

So, equation (i) can be written as,

$$\begin{aligned} \delta L &= \delta\vec{\phi} \cdot \sum_j (\vec{r}_j \times \dot{\vec{p}}_j + \vec{v}_j \times \vec{p}_j) \\ &= \delta\vec{\phi} \cdot \frac{d}{dt} \sum_j (\vec{r}_j \times \vec{p}_j) = \delta\vec{\phi} \cdot \frac{d\vec{L}'}{dt} \dots \dots \dots \text{(ii)} \end{aligned}$$

where $\vec{L}' = \sum_j(\vec{r}_j \times \vec{p}_j)$, the total angular momentum of the system with respect to O, a point on the axis of rotation.

But $\delta\phi$ is quite arbitrary. So, the condition $\delta L = 0$ gives, from equation (ii),

$$\frac{d\vec{L}'}{dt} = 0 \text{ i. e. } \vec{L}' = \text{constant}$$

So, because of isotropy of space, the total angular momentum of a closed system is conserved.

Examples-

1. Deduce the equation of motion of one dimensional harmonic oscillator using Hamilton's Principle.(KNU-2019)

Solution-

The Lagrangian for one dimensional harmonic oscillator can be given by,

$$L = T - V = \frac{1}{2}m\dot{x}^2 - \frac{1}{2}kx^2 \dots\dots\dots (i)$$

Now, according to Hamilton's principle or the variational principle $\int L dt$ or, $\int f(x, \dot{x}, t) dt$ is extremum.

Euler-Lagrange's equation is,

$$\frac{d}{dt} \left(\frac{\partial f}{\partial \dot{x}} \right) - \frac{\partial f}{\partial x} = 0$$

Here, $\frac{\partial f}{\partial x} = -kx$ and $\frac{\partial f}{\partial \dot{x}} = m\dot{x}$

Putting these values in equation (i) we get,

$$m\ddot{x} + kx = 0$$

This is the equation for one-dimensional harmonic oscillator.

2. Show that the shortest distance between two points in a plane is straight line.

Solution- Let A(x₁,y₁) and B(x₂,y₂) are two points in X-Y plane. An element of length ds of any curve (AP'B) passing through A and B is given by,

$$ds^2 = dx^2 + dy^2. \text{ or, } ds = \sqrt{1 + y'^2} dx \text{ where } y' = \frac{dy}{dx}$$

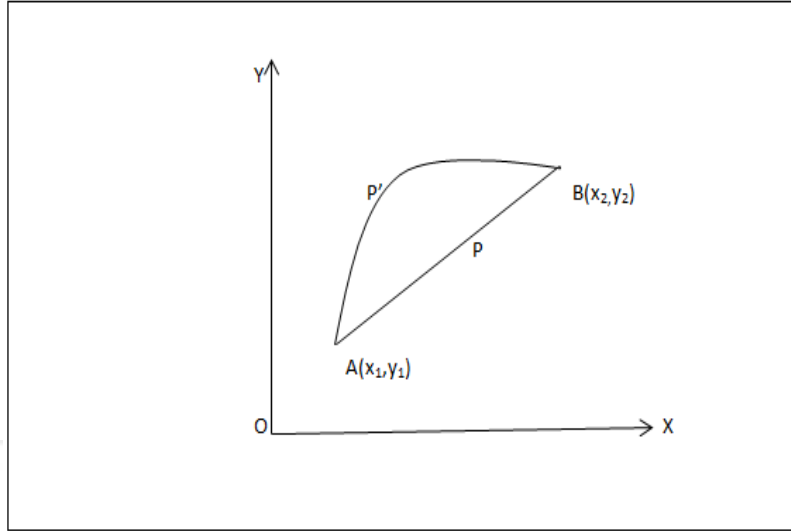

The total length of the curve from A to B is given by,

$$I = \int_A^B \sqrt{1 + y'^2} dx = \int_A^B f dx \dots \dots \dots \text{(ii)}$$

where $f = \sqrt{1 + y'^2}$

The length of the curve I will be minimum, when $\delta I = 0$. This means that f should satisfy the Euler-Lagrange's equation i.e. $\frac{d}{dx} \left(\frac{\partial f}{\partial y'} \right) - \frac{\partial f}{\partial y} = 0 \dots \dots \dots \text{(iii)}$

Here, $\frac{\partial f}{\partial y} = 0$ and $\frac{\partial f}{\partial y'} = \frac{y'}{\sqrt{1+y'^2}}$

Putting these values in equation (iii) we get,

$$\frac{d}{dx} \left(\frac{y'}{\sqrt{1 + y'^2}} \right) = 0$$

$$\frac{y'}{\sqrt{1+y'^2}} = C, \text{ where } C \text{ is a constant}$$

$$y'^2 = C^2(1 + y'^2)$$

On simplifying, we get, $y' = \frac{C}{\sqrt{1-C^2}} = a$, where a is another constant.

On integration we get,

$$y = ax + b \dots \dots \dots \text{(iv)}$$

where b is another constant.

Equation (iv) is the equation of a straight line. Therefore, the shortest distance between any two points in a plane is a straight line.

Exercise-

1. State the Hamilton's principle for a conservative system. Write down its modified form.
2. State and prove the Brachistochrone problem. (KNU-2019)
3. Show that the modified Hamilton's principle leads to the Hamilton's equation of motion.
4. Derive Euler-Lagrange equation from technique of calculus of variation. (KNU-2019)
5. What do you mean by isotropy of space? Show that isotropy of space leads to conservation of angular momentum of a system. (KNU-2019)

6. What do you mean by homogeneity of time? Show that homogeneity of time leads to the conservation of mechanical energy of a system.
7. A curve C joining the two points (x_1, y_1) and (x_2, y_2) is revolved about the Y -axis to form a surface of revolution. Determine the shape of the curve for which the area of the surface of revolution generated is minimum.
8. Derive the Hamilton's equation for a particle moving in a central force field.
9. Using Hamilton's canonical equations, derive the equation of motion of a particle moving in a force field in which the potential is given by $V = -k/r$, where k is positive.
10. Prove that the shortest distance between the points on the surface of a sphere is a straight line joining them.
11. Apply variational principle to show that the path of projectile is parabolic.
12. Show that for a spherical surface, the geodesics are the great circles.
13. If f_1 and f_2 are two function of y, y' and x , then prove the following relations-
 - a) $\delta(f_1 + f_2) = \delta f_1 + \delta f_2$
 - b) $\delta(f_1 f_2) = f_1 \delta f_2 + f_2 \delta f_1$

References-

- 1) S.N.Maithi & D.P.Raychaudhuri, Classical Mechanics and General Properties of Matter, New Age International Publishers, 2015
- 2) H.K.Dass, Advanced Engineering Mathematics, S.Chand & Company Ltd. (2009)
- 3) A. Beiser, Perspective of Modern Physics, 3rd Edition, New York, McGraw Hill (1969).

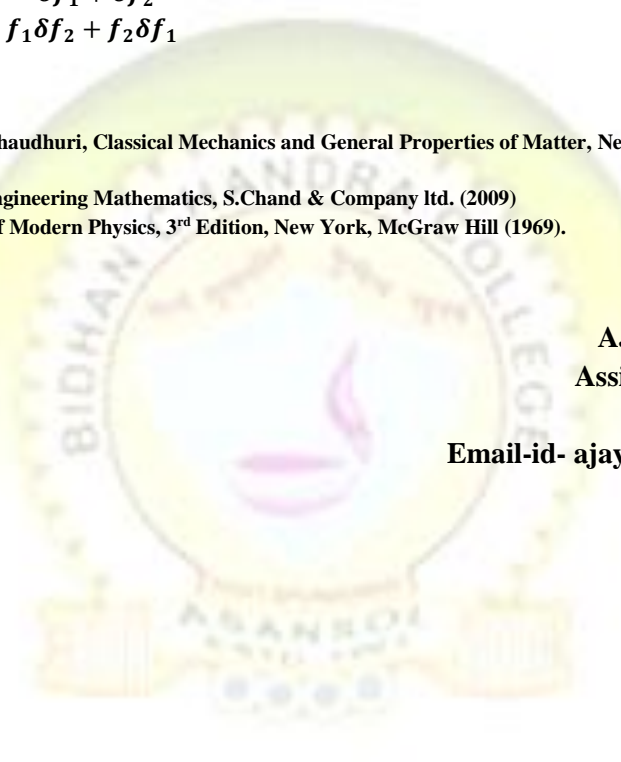

AJAY KUMAR SHARMA
Assistant Professor (Physics)
B.C.College, Asansol
Email-id- ajay888sharma@yahoo.co.in